

General Specifications

For high frequency (DC through 1GHz): Isolation 40dB minimum at 1GHz.
Insertion loss 0.5dB maximum at 1GHz.

Impedance 75 ohms

Innovative alternative to relay products

Highly reliable, self-cleaning twin contact mechanism with gold plating

Long total travel of .138" (3.5mm) for highly visible actuator position

Distinct audible and tactile feedback during actuation

Suited to high frequency applications (90MHz to 1GHz) such as CATV and communication equipment

Actual Size
with Tall Actuator

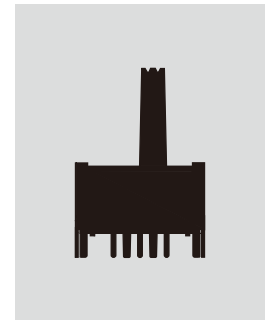

Distinctive Characteristics

Electrical Capacity (Resistive Load)

Logic Level: 0.4VA maximum @ 28V AC/DC maximum
(Applicable Range 0.1mA ~ 0.1A @ 20mV ~ 28V)
Note: Find additional explanation of operating range in Supplement section.

RF Ratings

Impedance: 75 ohms
Insertion Loss: 0.5dB maximum @ 1GHz
Isolation: 40dB minimum @ 1GHz

Other Ratings

Contact Resistance: 200 milliohms maximum
Insulation Resistance: 250 megohms minimum @ 500V DC
Dielectric Strength: 500V AC minimum for 1 minute minimum
Mechanical Life: 1,000 operations minimum
Electrical Life: 1,000 operations minimum
Contact Timing: Nonshorting (break-before-make)
Total Travel: .138" (3.5mm)

Environmental Data

Operating Temp Range: -30°C through +85°C (-22°F through +185°F)
Humidity: 90 ~ 95% humidity for 240 hours @ 40°C (104°F)
Vibration: 10 ~ 55Hz with peak-to-peak amplitude of 1.5mm traversing the frequency range & returning in 5 minutes; 3 right angled directions for 2 hours
Shock: 50G (490m/s²) acceleration (tested in 6 right angled directions, with 5 shocks in each direction)

Installation

Soldering Time & Temp: Wave Soldering: See Profile A in Supplement section.
Manual Soldering: See Profile A in Supplement section.
Cleaning: These devices are not process sealed. Hand clean locally using alcohol based solution.

TYPICAL SWITCH ORDERING EXAMPLE

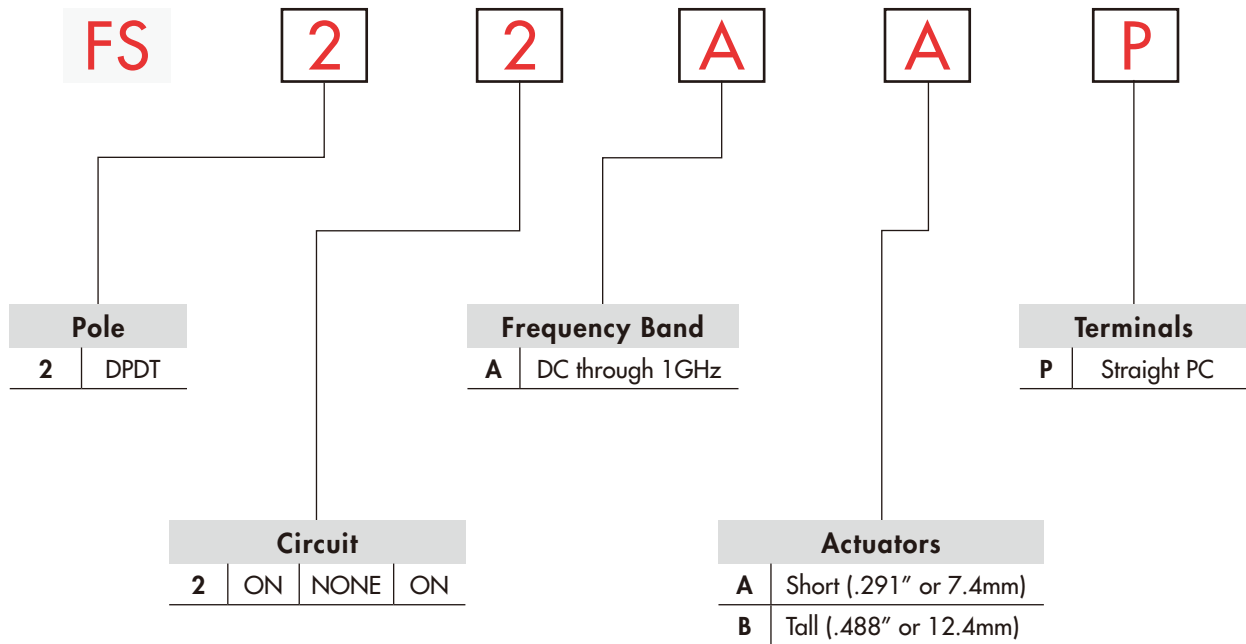

DESCRIPTION FOR TYPICAL ORDERING EXAMPLE

FS22AAP

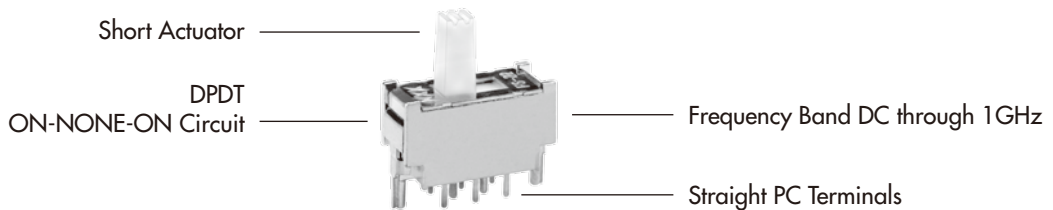

POLE & CIRCUIT

		Slide Position			Connected Terminals			Throw & Schematics
Pole	Model	Left	Center	Right	Left	Center	Right	
DP	FS22	ON	NONE	ON	2-1 5-4	NA	2-3 5-6	Note: Terminal numbers are not actually on the switch. DPDT

Toggle
Rockers
Pushbuttons
Illuminated PB
Programmable
Keylocks
Rotaries
Slides
Tactiles
Tilt
Touch
Indicators
Accessories
Supplement

HIGH FREQUENCY PERFORMANCE

RF Connection Options

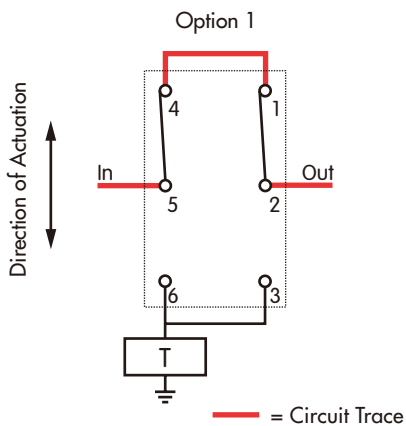

Isolation

>40dB @ 1GHz
(higher value is better)

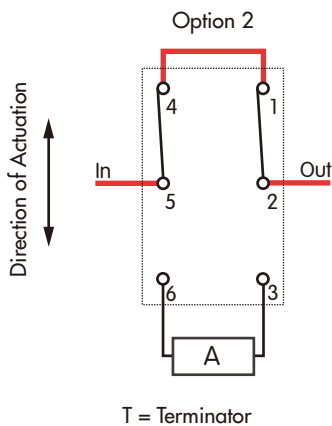
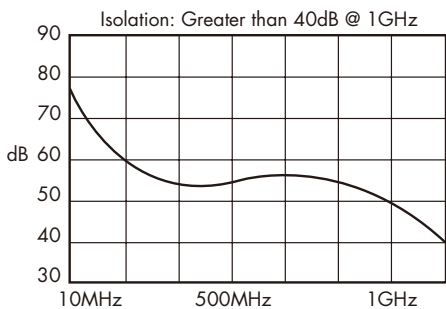

Insertion Loss

<0.5dB @ 1GHz
(lower value is better)

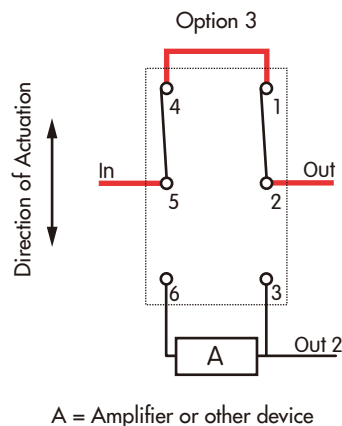
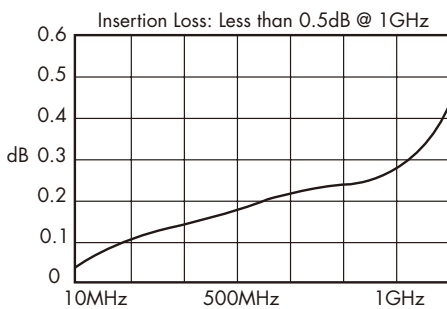

Standing Wave Ratio or Impedance Matching

Standing Wave = ratio between highest voltage & lowest voltage
(must always be more than 1)

VSWR (Voltage Standing Wave Ratio):
1:1 @ 1GHz

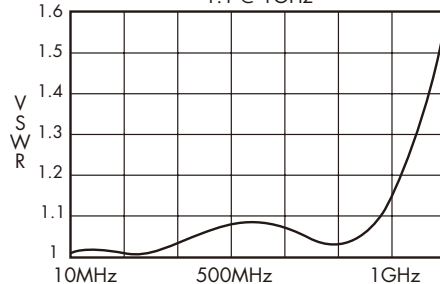

Note: The data above reflects the conditions using the FS switch on a test PCB with two coaxial connectors. High frequency applications require external connection on the PCB. Contact factory for details.

TYPICAL SWITCH DIMENSIONS

Short & Tall Actuators

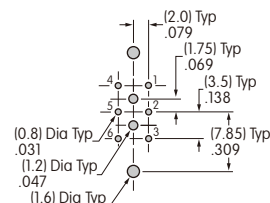
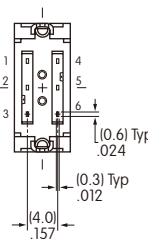
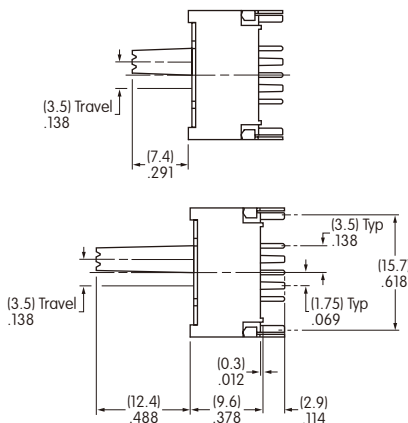
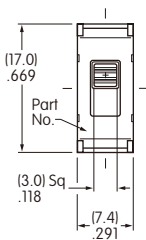

Actuator in LEFT position.

FS22ABP

